

FORD SYNC-3

Camera / Video interface

Compatible with 6.5" / 7" / 8" systems
with and without NAVI

SYNC 2.5 & SYNC 3

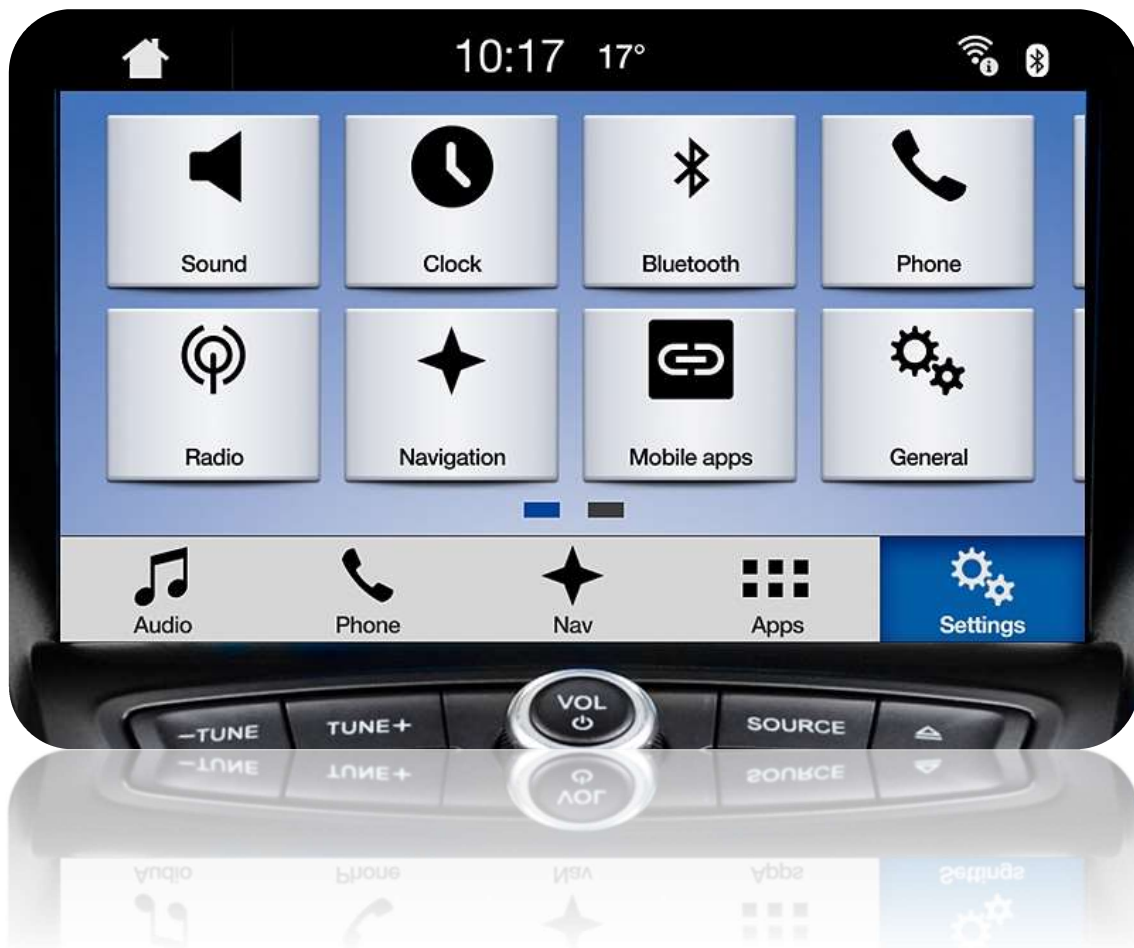

Article code: 300 208

Installation diagram:

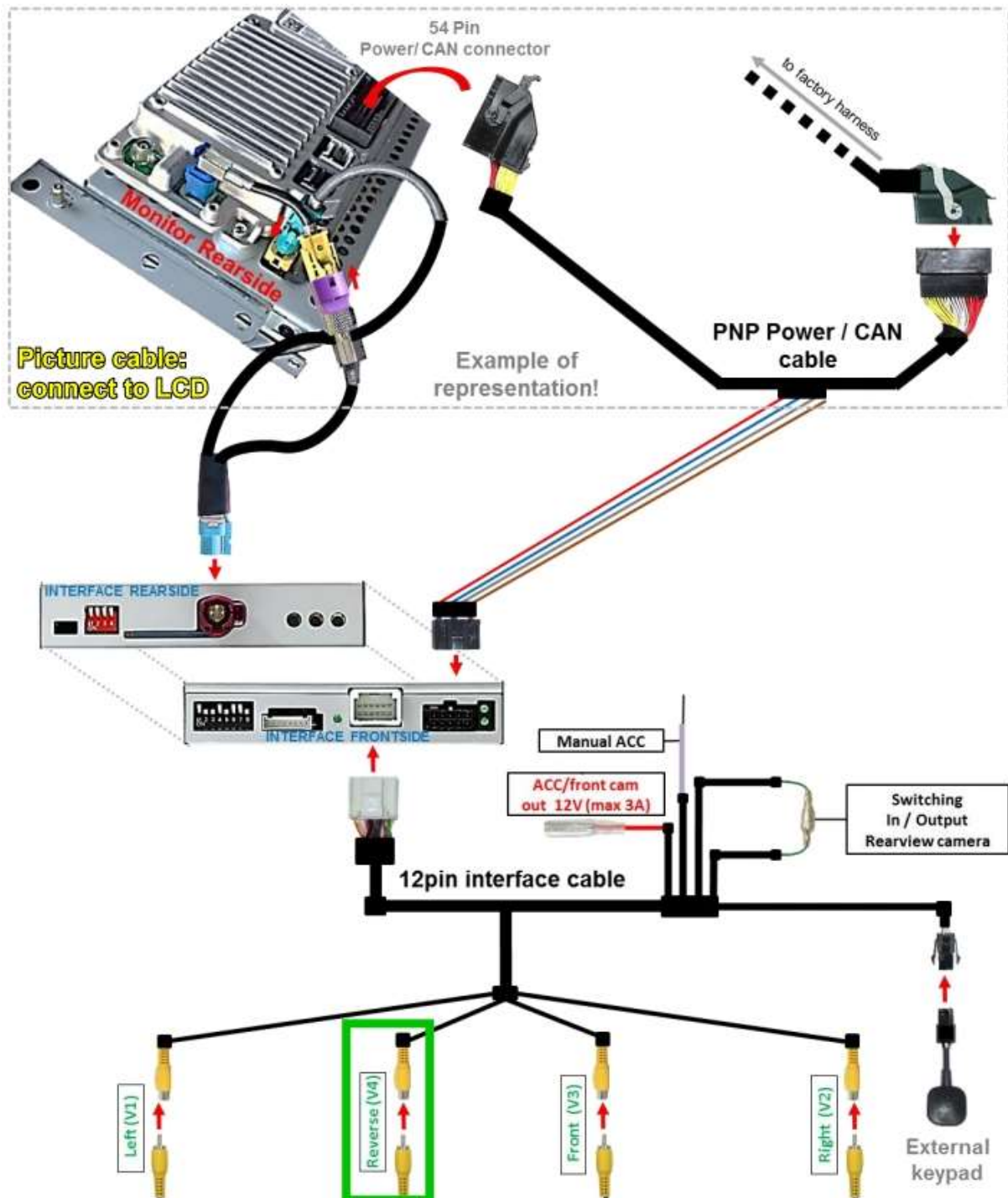

Tablet LCD:

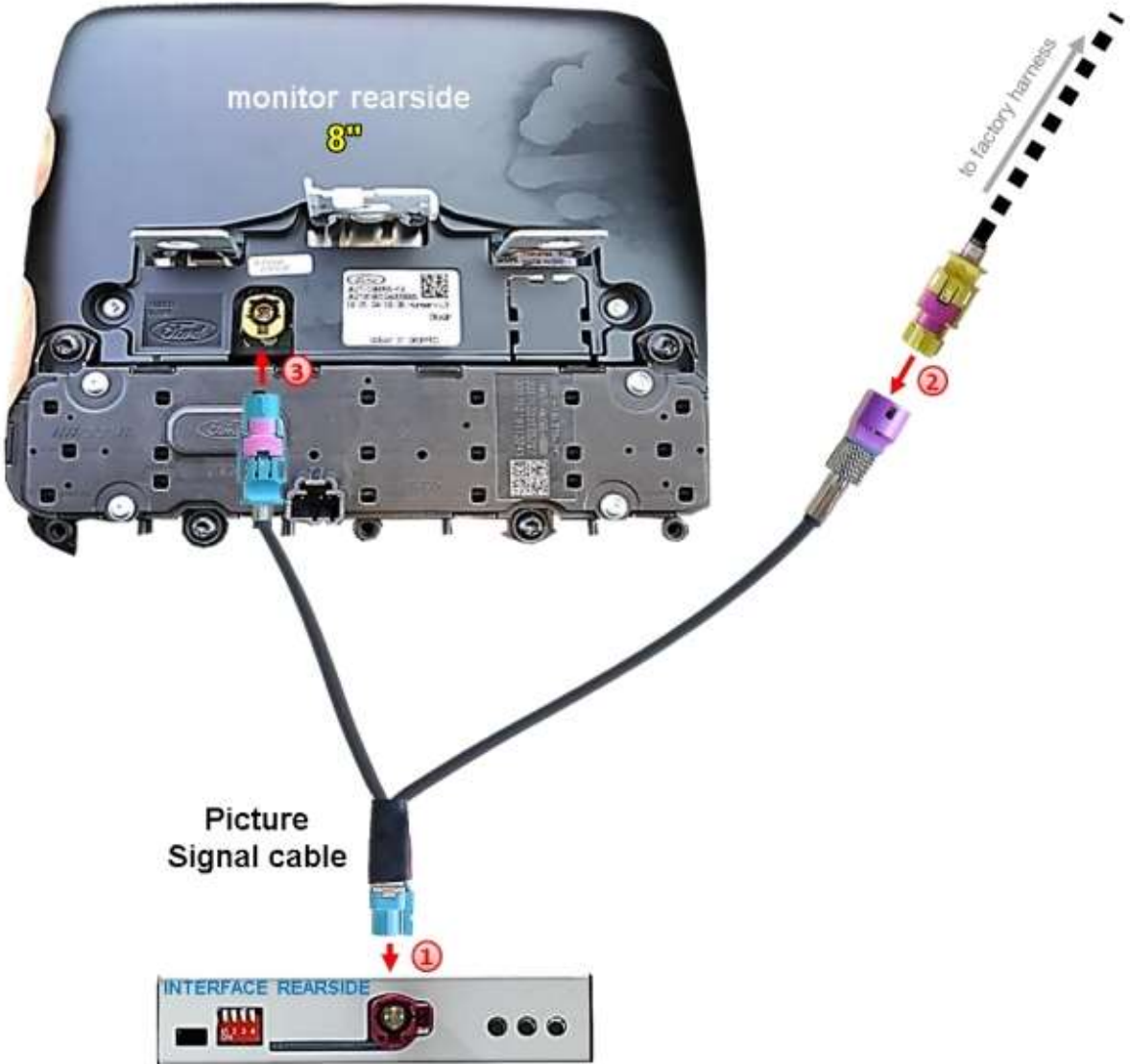

After installing the interface in between and power is on, the OEM image should be shown on screen.

Switching from OEM image to external sources:

- V1/V2/V3: use the switch key to switch from OEM image to V1-V2-V3.

- Rear CAM: when put gear in Reverse the interface switches automatically to Reverse camera input, usually detected by CANbus*.

*Unfortunately sometimes reverse it's not reacting by CANbus because the car can have different CAN protocol/codes. Also the guide lines can not be guaranteed.

In this case the **green Reverse-in** trigger wire of the interface should be connected to the analog 12V reverse light signal of the car.

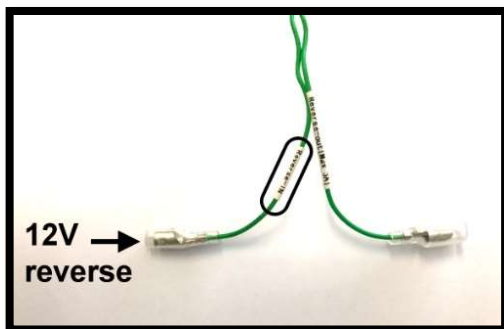

DIP-8 picture setting:

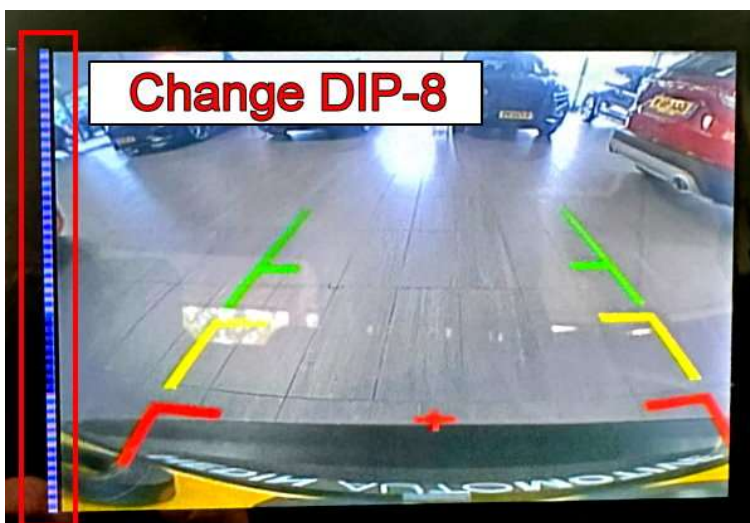

MENU / picture settings:

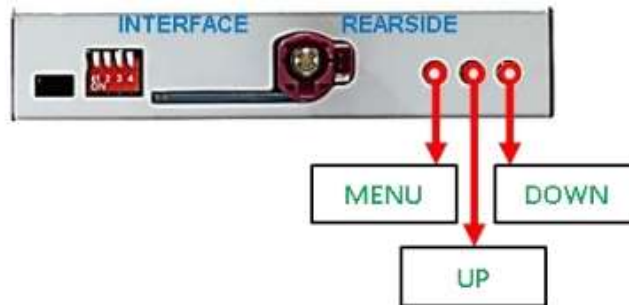

The picture settings are adjusted by the 3 buttons on the video-interface. Press the **MENU** button to open the OSD settings menu. To switch to the next menu item, pressing **UP** and **DOWN** will change the selected value. The buttons are embedded in the housing to avoid accidental changes during or after installation. The picture settings have to be done separately for AV1, AV2 and CAM while the corresponding input is selected and visible on the monitor.

Note: The OSD menu is only shown when a working video source is connected to the selected video-input of the interface.

The following settings are available

- Contrast
- Brightness
- Saturation
- Position H (horizontal) out of function
- Position V (vertical) out of function
- IR-AV1 out of function
- IR-AV2 out of function
- Guide-lines left out of function
- Guide-lines right out of function
- Guide lines CNTRL out of function (Dip switch 7 for guide lines)

The screenshot shows the OSD menu with the following settings:

Contrast	22
Brightness	50
Saturation	62
Position-H	6
Position-V	10
IR-AV1	None
IR-AV2	None
Guide-L	30
Guide-R	50
UI-CNTRL	0M
IR-CNTRL	10
IR-CNTRL	10

Head unit place in Ford Transit Custom:

