

PCM3 - Rear Camera - TV-Free

Rear-view camera-input and video-in-motion for Porsche vehicles with PCM 3.1 navigation systems

Only for vehicles WITHOUT factory rear-view camera

Product features

- Plug and play interface
- Integrated into the vehicle infotainment
- Rear-view camera input (+ coding)
- Rear-view camera power (+12V max. 400mA)
- Video-in-motion
- Automatic switching to rear-view camera input
- Optionally coding of ParkAssistant to retrofit factory PDC

Contents

1. Prior to installation

- 1.1. Delivery contents
- 1.2. Check compatibility of vehicle and accessories
- 1.3. Setting the Dip-switches of the CAN-Box
- 1.4. Pin-assignments

2. Connection schema

3. Installation

- 3.1. Interconnecting CAN-box, harness and factory navigation monitor
- 3.2. Connection to rear-view camera
- 3.3. Coding of the rear-view camera
 - 3.3.1. Decoding of the rear-view camera
- 3.4. Optionally coding of ParkAssistant to retrofit factory PDC
 - 3.4.1. Decoding of ParkAssistant
- 3.5. Alternatively coding and decoding of rear-view camera and ParkAssistant (e.g. if steering-wheel buttons not existing)

4. Activation of the video-in-motion function

5. Specifications

Legal Information

By law, watching moving pictures while driving is prohibited, the driver must not be distracted. We do not accept any liability for material damage or personal injury resulting, directly or indirectly, from installation or operation of this product. This product should only be used while standing or to display fixed menus or rear-view-camera video when the vehicle is moving, for example the MP3 menu for DVD upgrades.

Changes/updates of the vehicle's software can cause malfunctions of the interface. We offer free software-updates for our interfaces for one year after purchase. To receive a free update, the interface must be sent in at own cost. Labor cost for and other expenses involved with the software-updates will not be refunded.

1. Prior to installation

Read the manual prior to installation. Technical knowledge is necessary for installation. The place of installation must be free of moisture and away from heat sources.

1.1. Delivery contents

Take down the SW-version and HW-version of the interface boxes, and store this manual for support purposes.



1.2. Check compatibility of vehicle and accessories

Requirements

Vehicle Porsche Cayenne E2, Panamera, 911, Boxster, Cayman

Navigation PCM 3.1

Limitations

Video-in-motion Internal DVD video cannot be watched!

1.3. Setting the dip switches of the CAN-box

Vehicle/ navigation	Dip 1	Dip 2	Dip 3	Dip 4	Dip 5	Dip 6
PCM 3.1 with video-in-motion activated	ON	ON	OFF	OFF	OFF	ON
PCM 3.1 with video-in-motion deactivated	OFF	ON	OFF	OFF	OFF	ON

Note: Dip switch functions of the CAN-box

Dip 1 – activation TV-free

Dip 2 – rear-view camera existing

Dip 3 – Coding rear-view camera by white cable

Dip 4 – Coding ParkAssistant by white cable

Dip 5 – no function

Dip 6 – CAN-bus termination

1.4. Pin-assignments

Pin-assignment factory connector

Cable colour	Assignment	Pin No.
● Red	+12V battery	Pin 15
● Black	Ground	Pin 12
● Orange/brown	CAN-low	Pin 9
● Orange/purple	CAN-high	Pin 11

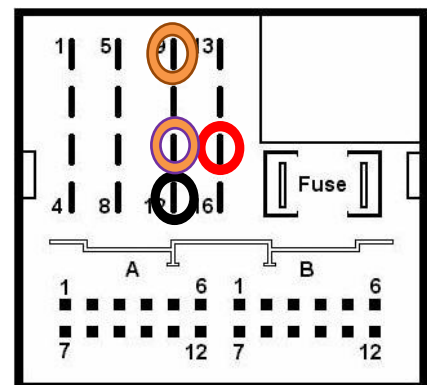

**No liability for vehicle wire colors and pin definition!
Possible changes by the vehicle manufacturer. The given
information must be verified by the installer.**

Pin-assignment of the CAN-box (Molex 8pin)

Cable colour	Pin-No.	Assignment
● Yellow	Pin 4	CAN-HIGH – connection to the head-unit
● Blue	Pin 3	CAN-LOW – connection to the head-unit
● Yellow/Black	Pin 8	CAN-HIGH – connection to the vehicle
● Blue/Black	Pin 7	CAN-LOW – connection to the vehicle
● Red	Pin 1	+12V permanent
● Black	Pin 5	Ground
● Green	Pin 2	+12V rear-view camera (max. 400mA)
● White	Pin 6	Alternatively coding

2. Connection schema

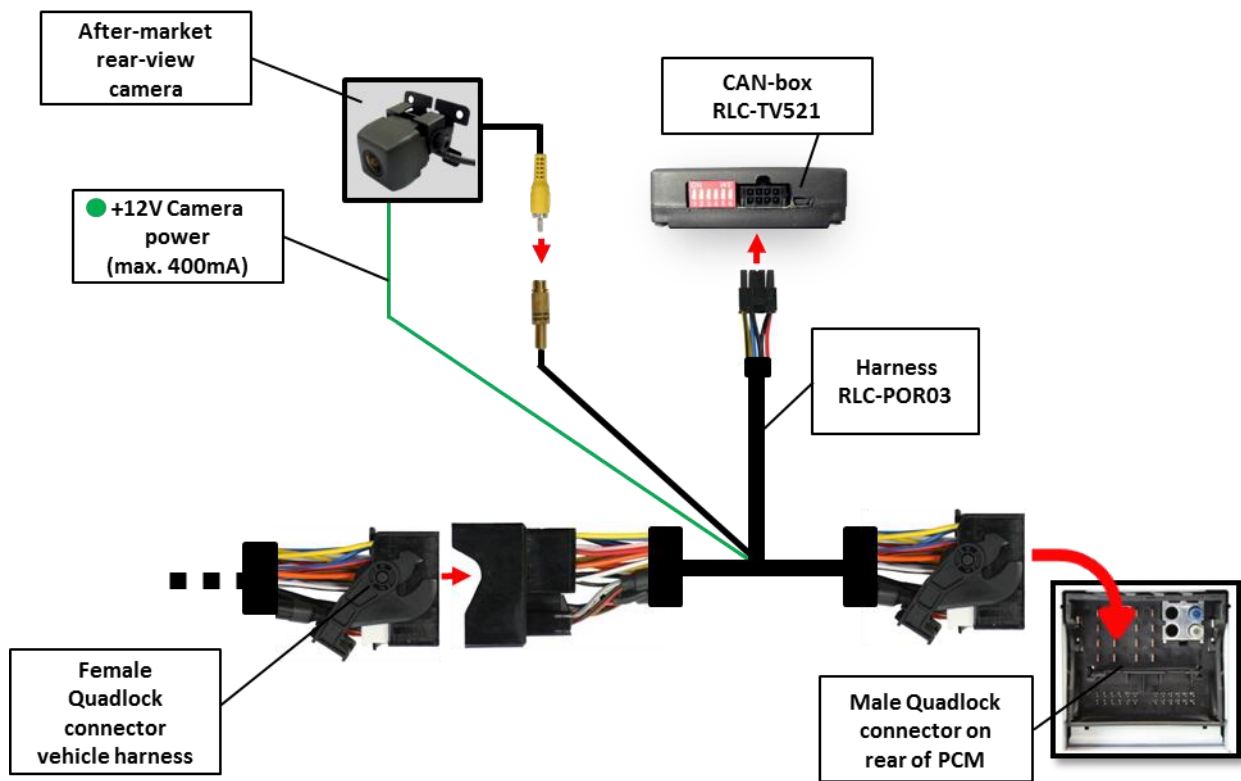

3. Installation

Switch off ignition and disconnect the vehicle's battery! If according to factory rules disconnecting the battery has to be avoided, it is usually sufficient to put the vehicle in sleep-mode. In case the sleep-mode does not show success, disconnect the battery with a resistor lead.

Place of installation is on rear of the head-unit.

3.1. Interconnecting CAN-Box, harness and factory navigation monitor

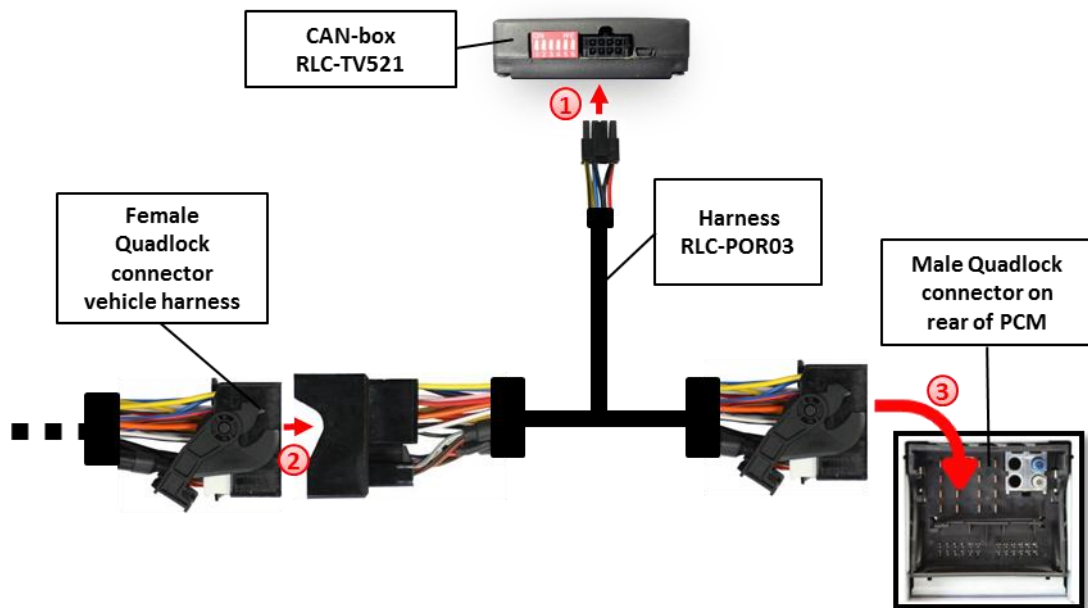

- ① Connect female 8pin Molex connector of harness RLC-POR03 to male 8pin Molex connector of CAN-box
- ② Transfer female Quadlock connector of vehicle harness from rear of the head-unit into male Quadlock connector of harness RLC-POR03.
- ③ Plug female Quadlock connector of harness RLC-POR03 into male Quadlock connector on the rear of the head-unit.

3.2. Connections to rear-view camera

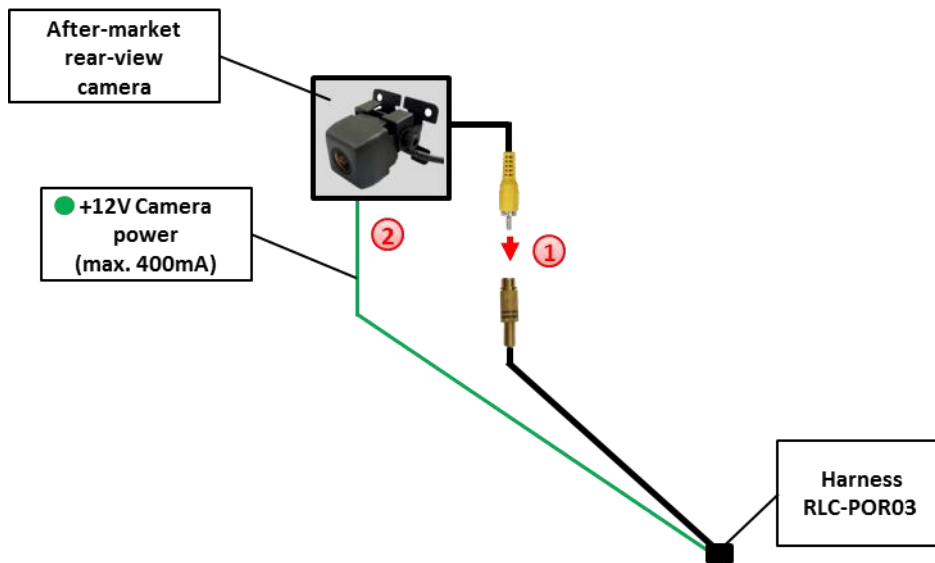

- ① Connect the video RCA of the rear-view camera to the female RCA connector of harness RLC-POR03.
- ② Connect the green cable of harness RLC-POR03 to the camera power supply (+12V max 400mA). The green cable is high when reverse gear is engaged (if ignition is off, too). The power will be deactivated from a speed of 20 km/h.

3.3. Coding of the rear-view camera



Steering-wheel buttons left



Steering-wheel buttons right

It is necessary to code the rear-view camera input of the PCM 3.1 to use it for an after-market rear-view camera.

1. Turn on ignition
2. Wait until the head-unit has booted
3. Press and hold steering-wheel button HASH KEY/MODE
4. Press and hold steering-wheel button ACCEPT (**observe the sequence!**)
5. Hold both buttons. During configuration the red and blue LED are blinking short inside the CAN-box (visible at the male 8pin Molex connector). The PCM makes a reset after 5-10 sec.
6. Disengage both steering-wheel buttons
7. The red and the blue LED inside the CAN-Box are glowing and the menu „Rear-view camera“ appears in the menu OPTION after a successful coding



3.3.1. Decoding of the rear-view camera

It is possible to decode the coding of the rear-view camera input as follows:

1. Turn on ignition
2. Wait until the head-unit has booted
3. Press and hold steering-wheel button HASH KEY/MODE
4. Press and hold steering-wheel button HANG UP (**observe the sequence!**)
5. Hold both buttons. During configuration the red and blue LED are blinking inside the CAN-box (visible at the male 8pin Molex connector). The PCM makes a reset after 5-10 sec.
6. Disengage both steering-wheel buttons
7. The red and the blue LED inside the CAN-Box are glowing and the menu „Rear-view camera“ disappears in the menu OPTION after a successful decoding

3.4. Optionally coding of ParkAssistant to retrofit factory PDC



Steering-wheel buttons left



Steering-wheel buttons right

It is necessary to code the ParkAssistant of the PCM 3.1 to retrofit factory PDC.

1. Turn on ignition
2. Wait until the head-unit has booted
3. Press and hold steering-wheel button BACK
4. Press and hold steering-wheel button ACCEPT (**observe the sequence!**)
5. Hold both buttons. During configuration the red and blue LED are blinking inside the CAN-box (visible at the male 8pin Molex connector). The PCM makes a reset after 5-10 sec.
6. Disengage both steering-wheel buttons
7. The red and the blue LED inside the CAN-Box are glowing and the menu „ParkAssistant“ appears in the menu OPTION after a successful coding



3.4.1. Decoding of the ParkAssistant

It is possible to decode the ParkAssistant as follows:

1. Turn on ignition
2. Wait until the head-unit has booted
3. Press and hold steering-wheel button BACK
4. Press and hold steering-wheel button HANG UP (**observe the sequence!**)
5. Hold both buttons. During configuration the red and blue LED are blinking inside the CAN-box (visible at the male 8pin Molex connector). The PCM makes a reset after 5-10 sec.
6. Disengage both steering-wheel buttons
7. The red and the blue LED inside the CAN-Box are glowing and the menu „ParkAssistant“ disappears in the menu OPTION after a successful decoding

3.5. Alternatively coding and decoding of rear-view camera and ParkAssistant (e.g. if steering-wheel buttons not existing)

Alternatively to coding by steering-wheel buttons the coding and decoding of rear-view camera and ParkAssistant can be done by loose white cable in connection with dip 3 and 4 of CAN-box .

Dip	Function	ON	OFF
Dip 3	Rear-view camera	Coding	Decoding
Dip 4	ParkAssistant	Coding	Decoding

1. Turn on ignition
2. Wait until the head-unit has booted
3. Set dip 3 and dip 4 of CAN-box (depending on the desired coding/decoding)
4. Put +12V for 5 sec. to the white cable
5. During configuration the red and blue LED are blinking short inside the CAN-box (visible at the male 8pin Molex connector). The PCM makes a reset after 5-10 sec.
6. The red and the blue LED inside the CAN-Box are glowing and the menu „Rear-view camera“ respectively “ParkAssistant” appears in the menu OPTION after a successful coding (or disappears after successful decoding)



Note: After a coding or decoding another coding isn't possible within the next 60 seconds!

If there are factory-PDC existing in the car you have to set Dip 4 to ON while coding. If not the factory PDC will be decoded!

4. Activation of the video-in-motion function

With dip1 to ON the video-in-motion function is activated permanently without disturbing the navigation performance.

5. Specifications

Operation voltage	10.5 – 14.8V
Stand-by power drain	<2mA
Operation power drain	~60mA
Power consumption	~0,08W
Temperature range	-30°C to +80°C
Weight	44g
Measurements (box only) W x H x D	76 x 27 x 54 mm